



SCHOTTKY BARRIER RECTIFIER

SRF2020C THRU SRF20100C

VOLTAGE RANGE

20 to 100 Volts

CURRENT

16.0 Amperes

FEATURES

- Plastic package has Underwriters Laboratory Flammability classification 94V-O Flame Retardant Epoxy Molding Compound
- Exceeds environmental standards of MIL-S-19500/228
- Low power loss, high efficiency
- Low forward voltage, high current capability
- High surge capacity
- For use in low voltage, high frequency inverters. Free wheeling, and polarity protection applications

MECHANICAL DATA

- Case: ITO-220AB full molded Plastic package
- Terminals: lead solderable per MIL-STD-202, Method 208
- Polarity: as marked
- Mounting position: Any
- Weight: 0.08ounce, 2.24 grams

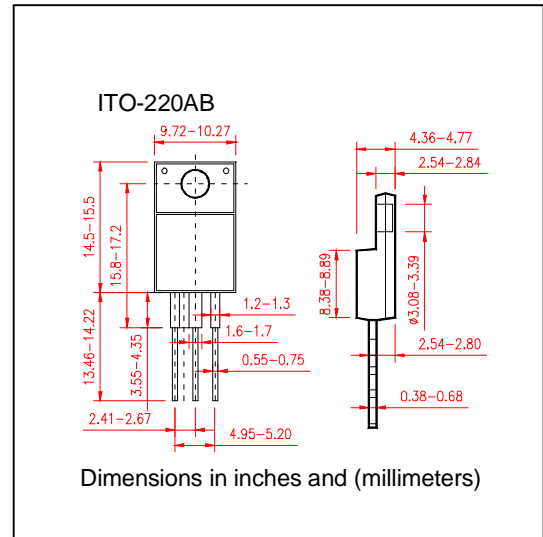

MAXIMUM RATINGS AND ELECTRICAL CHARACTERISTICS

- Ratings at 25°C ambient temperature unless otherwise specified
- Single Phase, half wave, 60Hz, resistive or inductive load
- For capacitive load derate current by 20%

	SYMBOLS	SRF 2020C	SRF 2030C	SRF 2035C	SRF 2040C	SRF 2045C	SRF 2050C	SRF 2060C	SRF 2080C	SRF ₂ 0100C	SRF ₂ 0150C	SRF ₂ 0200C	UNIT
Maximum Repetitive Peak Reverse Voltage	V_{RRM}	20	30	35	40	45	50	60	80	100	150	200	Volts
Maximum RMS Voltage	V_{RMS}	14	21	25	28	32	35	42	56	70	105	140	Volts
Maximum DC Blocking Voltage	V_{DC}	20	30	35	40	45	50	60	80	100	150	200	Volts
Maximum Average Forward Rectified Current At $T_C=90^\circ\text{C}$	$I_{(AV)}$	20.0											Amps
Peak Forward Surge Current 8.3ms single half sine wave superimposed on rated load (JEDEC method)	I_{FSM}	150											Amps
Maximum Forward Voltage at 10.0A per element	V_F	0.65					0.75			0.85			Volts
Maximum DC Reverse Current at rated DC Blocking Voltage per element	I_R	$T_C = 25^\circ\text{C}$											mA
		$T_C = 100^\circ\text{C}$											
Typical Junction Capacitance(Note2)	C_J	500											pF
Typical Thermal Resistance (Note 1)	$R_{\theta JC}$	4.0											$^\circ\text{C}/\text{W}$
Operating Storage Temperature Range	$T_J T_{STG}$	(-55 to +150)											$^\circ\text{C}$

Notes:

1. Thermal Resistance Junction to CASE
2. Measured at $V_R=4\text{v}$ and $f=1\text{MHz}$



SCHOTTKY BARRIER RECTIFIER

SRF2020C THRU SRF20100C

VOLTAGE RANGE 20 to 100 Volts
CURRENT 20.0 Ampere

RATING AND CHARACTERISTIC CURVES SRF2020C THRU SRF20100C

FIG.1-TYPICAL FORWARD CURRENT DERATING CURVE

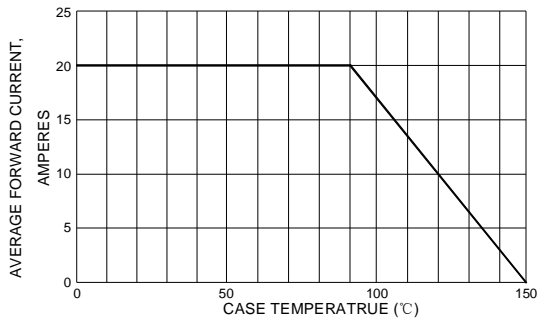

FIG.3-TYPICAL INSTANTANEOUS FORWARD CHARACTERISTIC

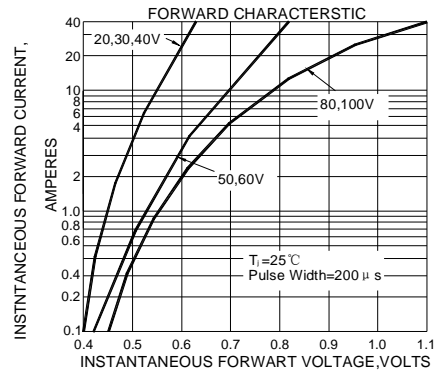

FIG.2-TYPICAL REVERSE CHARACTERISTICS

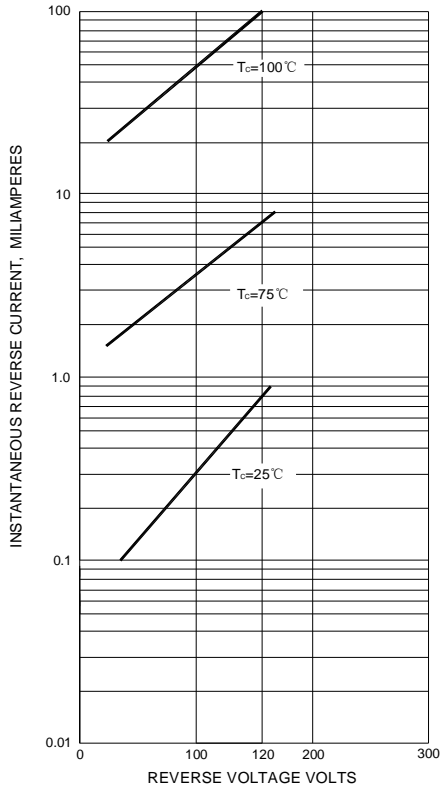

FIG.4-MAXIMUM NON-REPETITIVE SURGE CURRENT

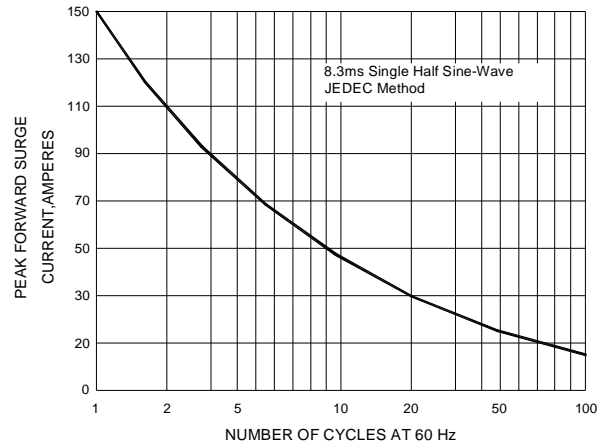

FIG.5-TYPICAL JUNCTION CAPACITANCE

